

**Features**

- Operation Voltage DC 12V~80V.
- 0.1V current sense voltage reference.
- Directly drive 1~8 Series 1W LED.
- Excellent line and load regulation.
- Internal Optimize Power HV-MOSFET.
- Built in Thermal Shutdown Function.
- Built in Current Limiting Function.
- Built in Soft-Start Circuit.
- Available in SOIC-8 package.
- Up to 97% efficiency.

**Applications**

- LED Lighting & LED LAMP
- General purpose LED lighting

**General Description**

The XL8001 is a monolithic high voltage switching regulator with PFM that is specifically designed to operate from a 12V~80V DC power supply.

The XL8001 is a high efficiency LED driver switching regulator. The LED string is driven at DC constant current rather than constant voltage, thus providing constant light output and enhanced reliability.



SOIC-8

Figure1. Package Type of XL8001

**Pin Configurations**

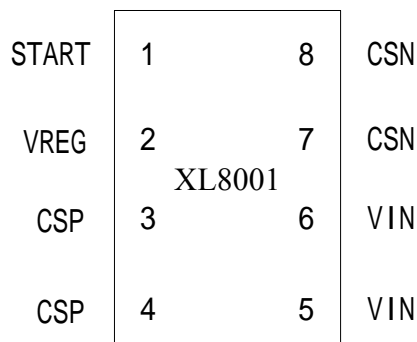

Figure2. Pin Configuration of XL8001 (Top View)

Table 1: Pin Description

Pin Number	Pin Name	Description
1	START	Internal soft start Pin.
2	VREG	Internal Voltage Regulation Pin. (The VREG is about 8V)
3,4	CSP	Current Sense Positive Pin. (The current sense voltage is 0.1V)
5,6	VIN	Input high voltage Pin. (Operation voltage 12V~80V)
7,8	CSN	Current Sense Negative Pin.

**Function Block**

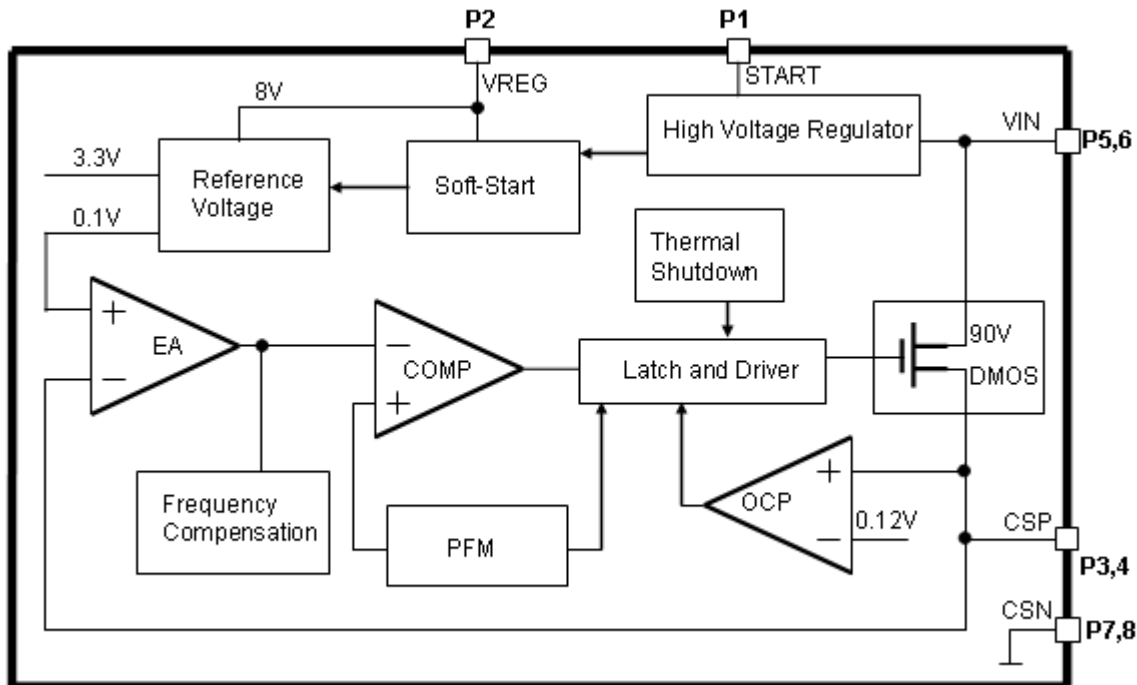

Figure3. Function Block Diagram of XL8001

**Typical Application Circuit**

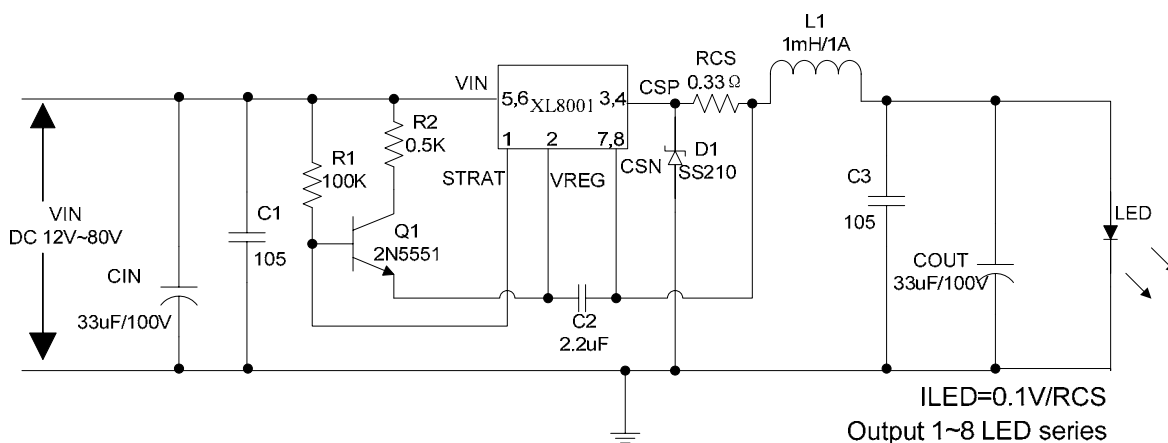

Figure4. XL8001 Typical Application

80V 0.5A High Efficiency Buck PFM LED Constant Current Driver

XL8001

**Ordering Information**

Order Information	Marking ID	Package Type	Packing Type Supplied As
XL8001E1	XL8001E1	SOP-8L	2500 Units on Tape & Reel

XLSEMI Pb-free products, as designated with “E1” suffix in the par number, are RoHS compliant.

**Absolute Maximum Ratings ( Note1 )**

Parameter	Symbol	Value	Unit
Input Voltage	V <sub>in</sub>	-0.3 to 90	V
Power Dissipation	P <sub>D</sub>	Internally limited	mW
Thermal Resistance (SOP-8L) (Junction to Ambient, No Heatsink, Free Air)	R <sub>JA</sub>	100	°C/W
Operating Junction Temperature	T <sub>J</sub>	-40 to 125	°C
Storage Temperature	T <sub>STG</sub>	-65 to 150	°C
Lead Temperature (Soldering, 10 sec)	T <sub>LEAD</sub>	260	°C
ESD (HBM)		>3000	V

**Note1:** Stresses greater than those listed under Maximum Ratings may cause permanent damage to the device. This is a stress rating only and functional operation of the device at these or any other conditions above those indicated in the operation is not implied. Exposure to absolute maximum rating conditions for extended periods may affect reliability.

**80V 0.5A High Efficiency Buck PFM LED Constant Current Driver**

**XL8001**

**XL8001 Electrical Characteristics**

T<sub>a</sub> = 25 °C; unless otherwise specified. Reference test circuit figure4

Symbol	Parameter	Test Condition	Min.	Typ.	Max.	Unit
VCSP	CSP Voltage	VIN=60V; Iled=300mA; Series 1~8 1W LED	95	100	105	mV
Efficiency	η	VIN=60V; Iled=300mA; Pout=8W	-	93.9	-	%

**Electrical Characteristics (DC Parameters)**

Parameters	Symbol	Test Condition	Min.	Typ.	Max.	Unit
Input operation voltage	VIN		12		80	V
Switching Frequency	Fosc	Figure4 (8*1W) VIN=60V	65.2	81.5	97.8	KHz
Max. Duty Cycle	D <sub>MAX</sub>			85		%
VDMOS Drain-Source Breakdown Voltage	V <sub>BRDS</sub>	V <sub>GS</sub> =0V, I <sub>DS</sub> =250uA	90			V
VDMOS Drain-Source on resistor	R <sub>DS(on)</sub>	I <sub>DS</sub> =0.5A, V <sub>GS</sub> =8V		100	120	mOhm
Thermal Shutdown	OTP	T <sub>j</sub>		160		°C
Thermal Shutdown Window				20		°C

**80V 0.5A High Efficiency Buck PFM LED Constant Current Driver XL8001**

**[1] Typical System Application (VIN=12V~80V)**

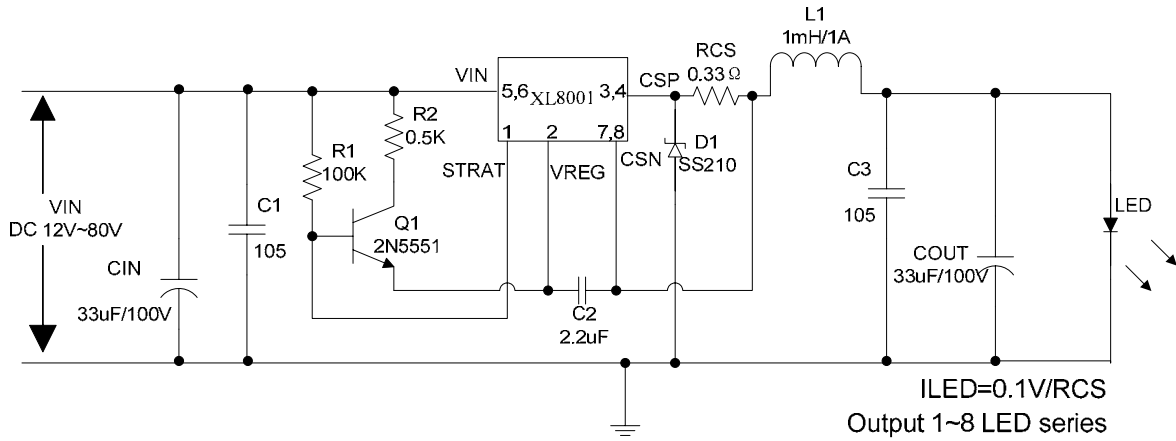

Figure5. XL8001 System Application at VIN=12V~80V Schematic

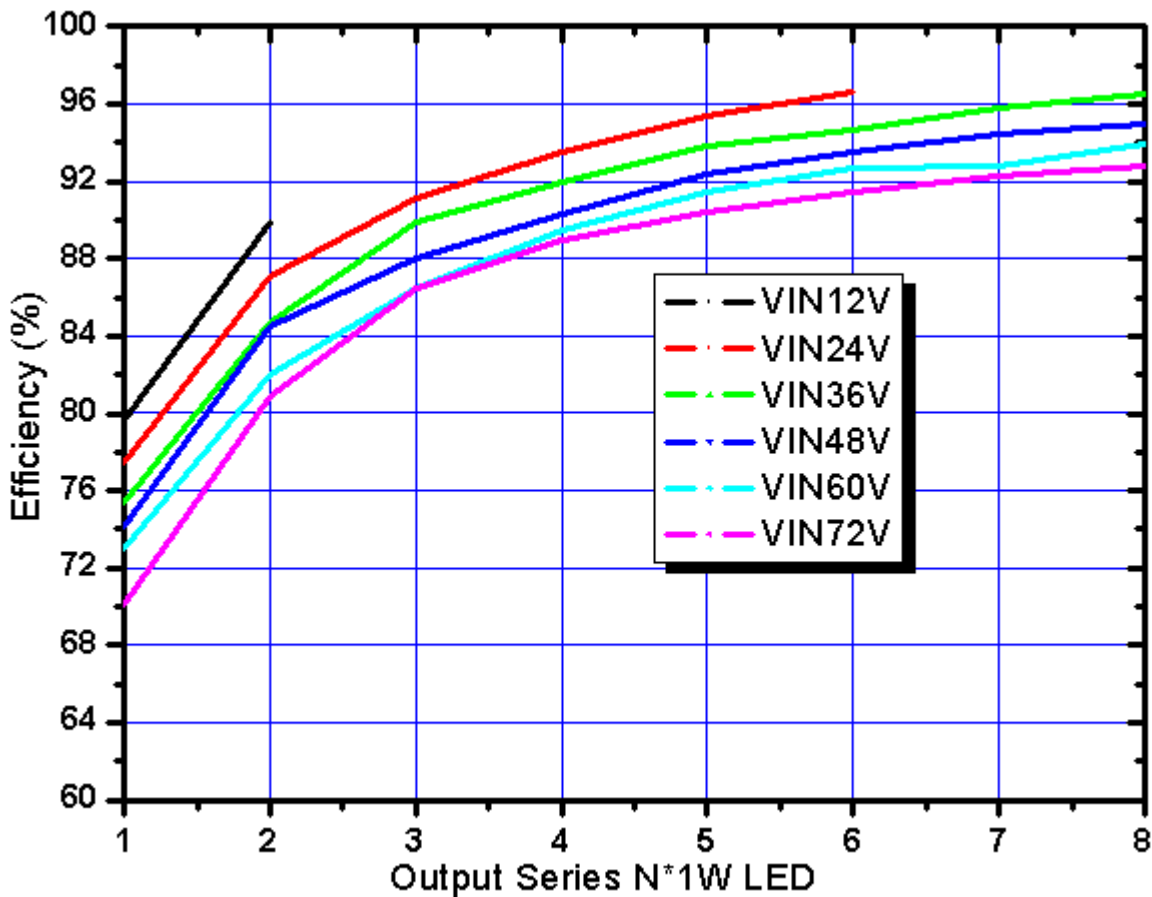

Figure6. XL8001 System Application at VIN=12V~80V Efficiency Curve

**80V 0.5A High Efficiency Buck PFM LED Constant Current Driver**

**XL8001**

Table1: Figure5 Input VIN=12V/24V/36V/48V/60V/72V system parameters table:

LED String 1W*N	VIN=12V			VIN=24V			VIN=36V		
	FOSC	Pout	Efficiency	FOSC	Pout	Efficiency	FOSC	Pout	Efficiency
1	21.9K	1.02W	79.6%	25.5K	1.035W	77.5%	25.6K	1.059W	75.4%
2	22.3K	1.97W	89.9%	26.6K	2.022W	87.1%	39.3K	2.042W	84.7%
3				41.5K	2.912W	91.1%	49.2K	3.012W	89.9%
4				40.5K	3.86W	93.5%	55.0K	3.943W	92.0%
5				33.4K	4.831W	95.4%	57.1K	4.865W	93.8%
6				20.9K	5.575W	96.6%	55.6K	5.728W	94.7%
7							50.7K	6.592W	95.8%
8							42.4K	7.402W	96.5%
LED String 1W*N	VIN=48V			VIN=60V			VIN=72V		
	FOSC	Pout	Efficiency	FOSC	Pout	Efficiency	FOSC	Pout	Efficiency
1	24.8K	1.070W	74.2%	23.9K	1.097W	73.0%	22.8K	1.111W	70.1%
2	39.3K	2.073W	84.5%	38.6K	2.120W	82.0%	37.3K	2.157W	80.9%
3	51.1K	3.05W	88.0%	51.1K	3.122W	86.5%	50.1K	3.176W	86.5%
4	59.8K	3.994W	90.3%	61.3K	4.085W	89.5%	61.0K	4.165W	89.0%
5	66.1K	4.933W	92.4%	69.6K	5.063W	91.4%	70.3K	5.141W	90.4%
6	69.4K	5.836W	93.5%	75.6K	5.968W	92.7%	77.8K	6.062W	91.4%
7	70.0K	6.690W	94.5%	79.5K	6.850W	92.8%	98.7K	6.980W	92.3%
8	68.3K	7.542W	95.0%	81.5K	7.723W	93.9%	88.0K	7.847W	92.8%

**Schottky Diode Selection Table**

VR	1A	3A				
20V	1N5817	SS32	SK32	1N5820	MBR320	SR302
30V	1N5818	SS33	SK33	1N5821	MBR330	SR303
40V	1N5819	SS34	SK34	1N5822	MBR340	SR304
50V		SS35	SK35		MBR350	SR305
60V		SS36	SK36		MBR360	SR306
70V		SS37	SK37			SR307
80V		SS38	SK38			SR308
90V		SS39	SK39			SR309
100V		SS310	S310			SR310

**Package Information**

**SOP8 Package Mechanical Dimensions**

SOIC-8

Unit: mm(inch)

